

WRAP AROUND PACKER



**RECOPAK**  
PACKAGING MACHINERY SOLUTIONS



MODULAR DESIGN

QUICK SIMPLE CHANGE OVER

ROBUST LASER CUT FRAMEWORK

RELIABLE CONSISTENT OPERATION

OPERATOR FRIENDLY CONTROL SYSTEM

100% AUSTRALIAN DESIGNED AND MANUFACTURED

# WRAP AROUND PACKER

## Machine Description

The Recopak Intermittent Wraparound Case Packers caters for speeds of upto 15 cases per minute. All Machines in the range feature Servo Drive Technology offering the customer State of the Art Performance.

The Recopak Wraparound case packer is an intermittent motion machine able to pack bottles, jars, cans or packets into wraparound style cases. This machine features an individually designed product infeed system to meet customer specific requirements.

The unique dual servo driven case transfer system enables case length selection to be done via the operator interface screen, eliminating difficult mechanical size change adjustments. The HMI rotates about the centreline of the machine to provide operator control from either side of the machine.

This machine can be supplied to handle either Internal or External Glue Lap.

Full size guard doors on both sides of the machine offer complete access for operator intervention. Fully Automatic adjusting product paddles guarantee higher reliability and precision when changing to a new carton size.



### Technical Data:

- Main Voltage:** 400 Volt – 3 Phase (5 wire)
- Control Voltage:** 24 Volt DC
- Control System:** Allen Bradley PLC (Standard)
- Pneumatics:** FESTO (Standard)
- Electrical Load:** 10 kW
- Air Supply:** Clean dry air at minimum Pressure of 560 Kpa
- Speed:** Up to 15 Cases per minute pending product and case size
- Hot Melt:** Nordson Model Problue 7 (Standard)

### Machine Features:

- Fully Automatic adjusting product paddles.
- Swivel HMI Screen allows operation from either side of the machine.
- Quick Changeover easily configured by hand wheels and metric rulers.
- Extended magazine can hold approximately 200 case blanks.



#### Case infeed Magazine

Ergonomic design for ease of case loading. Standard magazine holds upto 150 case blanks. Extended magazine available to suit the customer needs. Operator friendly changeover between case sizes.

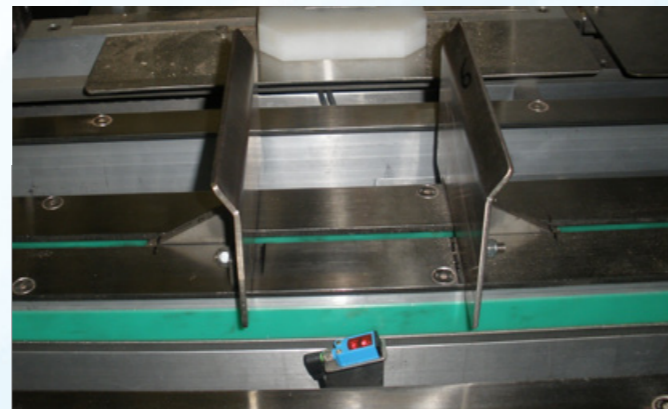

#### Servo Driven Product Paddles

Servo driven product paddles automatically adjust upon format selection, which guarantees ultimate precision when changing to a new carton size.

#### Case Handling Range

| (mm)       | A    | B   | L   | W   | H   |
|------------|------|-----|-----|-----|-----|
| <b>Min</b> | 500  | 330 | 230 | 130 | 100 |
| <b>Max</b> | 1300 | 700 | 500 | 340 | 300 |

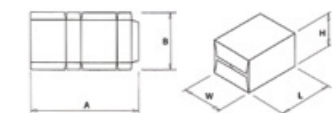



**RECOPAK**  
PACKAGING MACHINERY SOLUTIONS

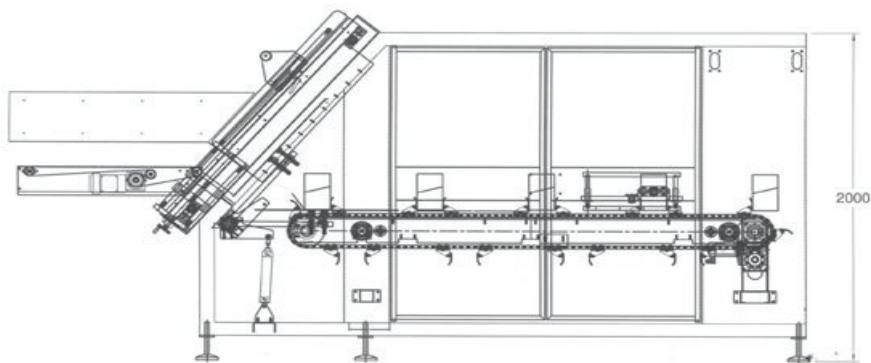
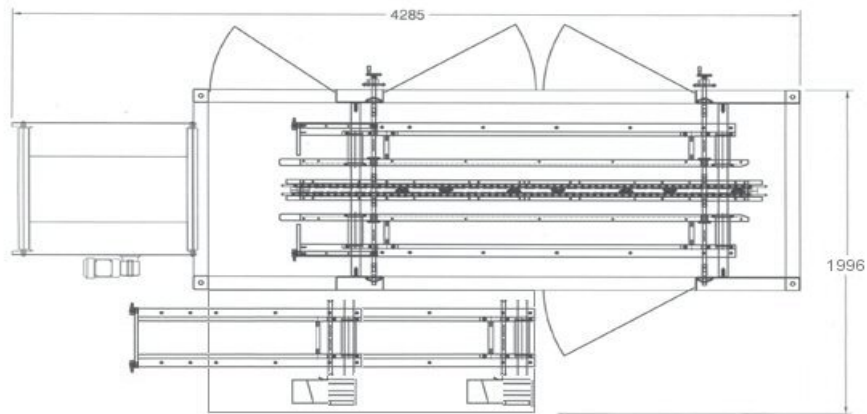

## About Recopak

Recopak are the leaders in the design and manufacture of quality packaging machinery. Our product range is continually expanding to suit the ever changing needs of the industry.

In addition to the Recopak range we have carefully selected partners to work with; which enables us to also offer you the most innovative and up-to-date packaging solutions for your company needs.

Recopak employs highly skilled and qualified personnel to provide a complete package from sales, design, installation, after sales technical support and spare parts.

Innovative by design, Recopak machines are finished to the highest standard and have aesthetically pleasing appearance, robust construction, quick - simple size change, accessibility for maintenance and operator safety are a major priority.

### Tougher

Packaging equipment needs to have longevity built in. At Recopak our equipment is made to last! We design toughness into every product we manufacture, utilizing the highest quality materials ensures our quality control is second to none.

### Smarter

We are manufacturing smarter packaging machinery to make life easier for you and your team....Easy to operate, easy to maintain and designed to keep you on-line for maximum productivity.

### Safety

Your most valuable asset is your staff. Our machinery is designed to put their safety first. We comply to all current Australian Safety Standards.

### Innovative

Our Research & Development Team continually navigate the globe for the latest innovations and best practices. We incorporate these features into our equipment so you get the latest technological solutions today.

### Support

Recopak machines are completely manufactured "In House" by our team of designers, engineers and technicians; that is why we have the expertise to offer our customers complete after sales service and a support that is "second to none".

## RECOPAK MACHINERY PTY LTD

18 Schubert Street ( P.O. Box 385 )  
COBRAM, Victoria, 3644

Telephone: +61 3 5871 1955

Email: [admin@recopak.com.au](mailto:admin@recopak.com.au)

[www.recopak.com.au](http://www.recopak.com.au)